

OPERATION MANUAL
Model H-422
4-Band Trap Di-Pole Antenna

Features:

- 1) Newly designed Non-Space, Wide Band di-pole antenna.
- 2) Can be used both Straight-type and/or V-type. When used as V-type, ready On-Air from low location of 3m high from the ground.
- 3) CBL-2000, high power 2KW/SSB balun, is included as the standard accessory, which helps for preventing TVI, BCI and other interfares.
- 4) Specially developed High Power Trap Coils assure high power QSO constantly.
- 5) The 3 Radiator Sizes - LOW, MID, HIGH - were illustrated for much FB transmission at 21 & 28MHz.

Specifications:

Frequencies : 7, 14, 21, 28MHz.
Impedance : 50 ohm
V. SWR : Less than 1 : 1.5 at center freq.
Max In-put Power: 1KW / SSB
Connector : M-J (SO-239 type)
Max wind velocity: 35m / sec.
Length : 10.3m (Streight type)
 7.4m (V-type)
Weight : 5.4 kgs.
Rotation Radius : 5.3m (Streight type)
 3.8m (V-type)
Suitable mast dia.: 38 - 62mm ϕ

● Measurement & SWR Characters:
(Streight - Type)

- ◎ CW-operation - (L) location
- ◎ SSB-operation - (M) location
- ◎ FM(28MHz) (H) location

———— 20m high from ground. - - - - 5m high from ground.

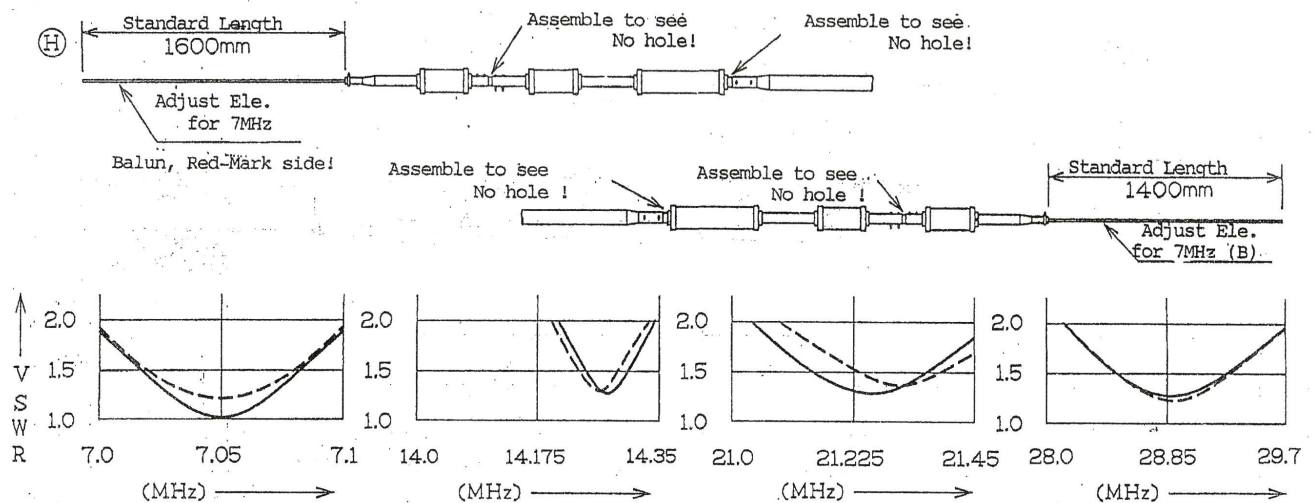
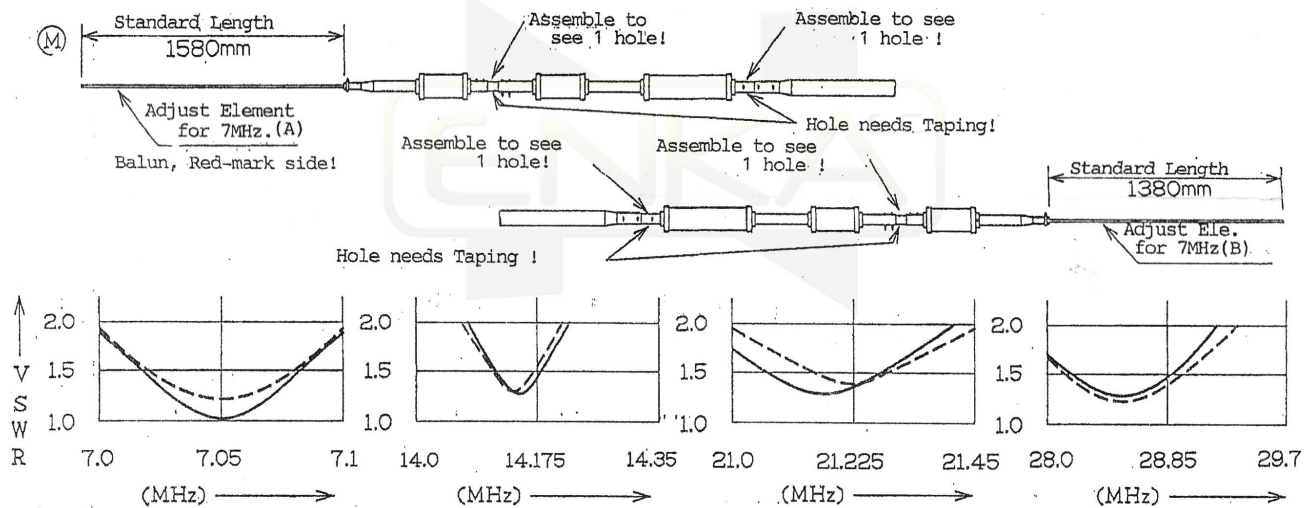
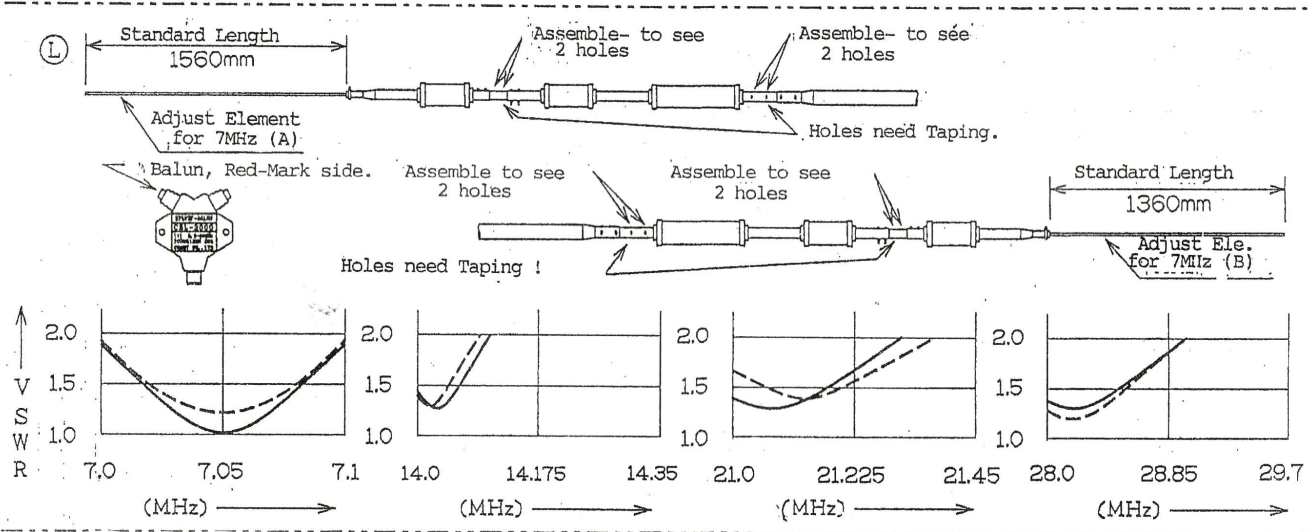

** You can change Center freq. of 7MHz by sliding the 7MHz Adjust Element, without any influence to other frequencies.

** Shift of 7MHz band per each 1cm, is 15KHz.

** Difference of Left & Right 7MHz element is to be 200mm constantly.

● Measurement & SWR Characters
(V-type)

⊙ CW-operation - (L) location

⊙ SSB-operation - (M) location

⊙ FM(28MHz) - (H) location

————— 20m high from ground - - - - - 5m high from ground

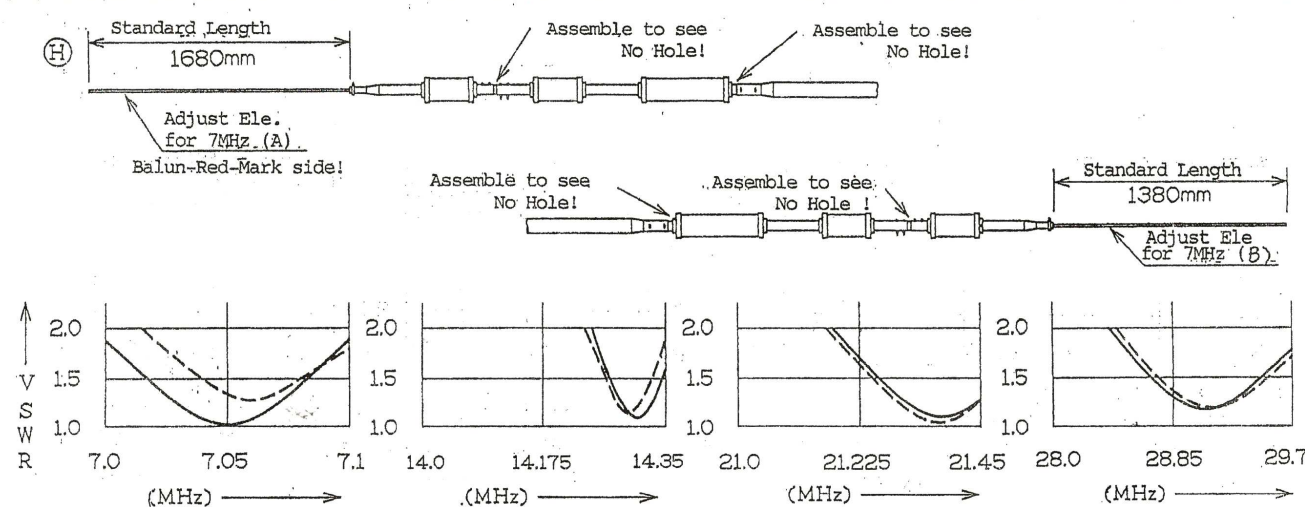
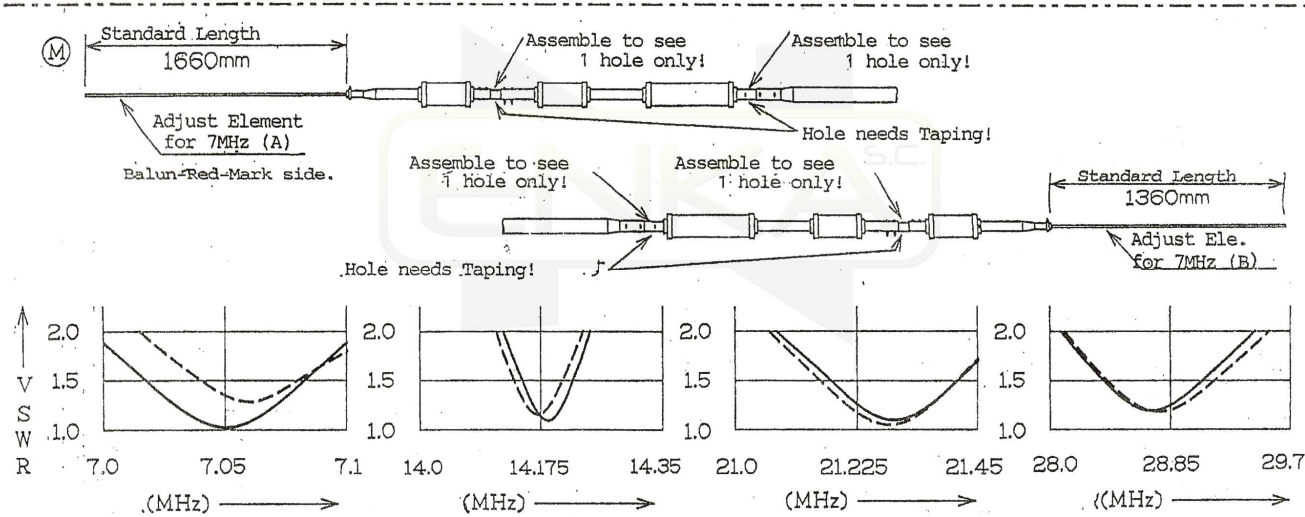
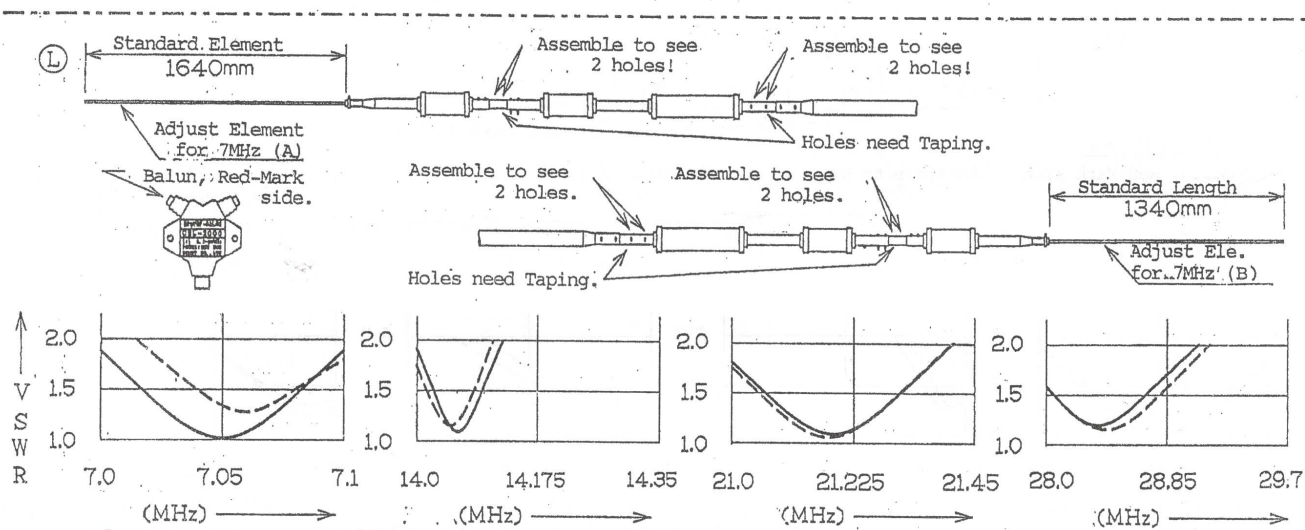

** You can change Center Freq. of 7MHz by sliding the 7MHz adjust Element, without any influence to other frequencies.

** Shift of 7MHz band per each 1cm, is 15KHz.

** Difference of Left & Right 7MHz Element is to be 300mm.

★ FULL Assembly
(Straight-Type)

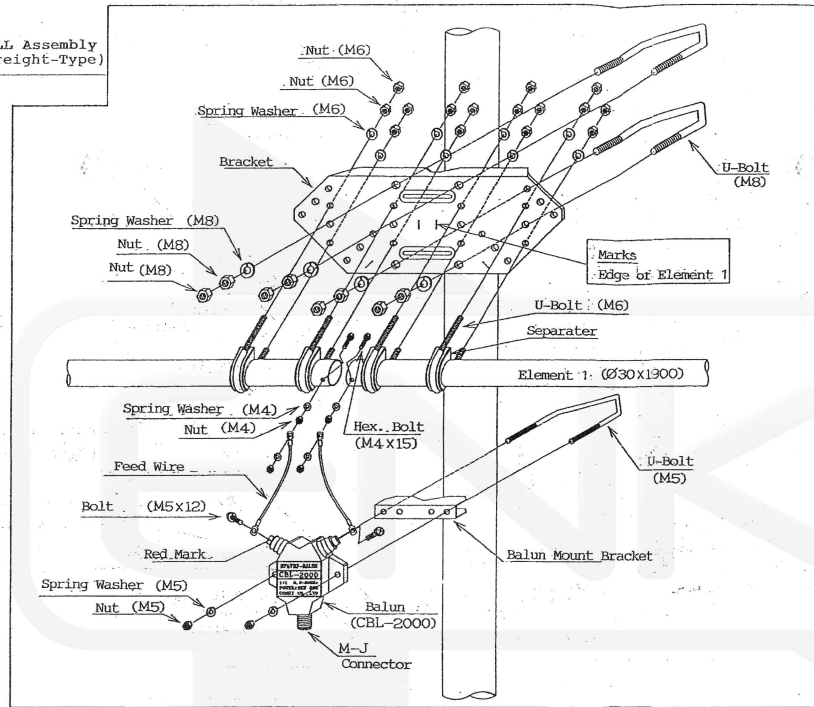

★ PARTS' LIST

Nos.	Parts' Names	Qty
1	Element 1 (Ø30 x 1900)	2
2	Trap	2
3	Trap for 14MHz	2
4-1	Adjust Element for 7MHz(Ø10x1500)	1
4-2	Adjust Element for 7MHz(Ø10x1750)	1
5	Mounting Bracket Assembly	-
5-1	Bracket	1
5-2	Separator	4
5-3	U-Bolt (M6)	4
5-4	Spring Washer (M6)	8
5-5	Nut (M6)	16
5-6	U-Bolt (M8)	2
5-7	Spring Washer (M8)	4
5-8	Nut (M8)	8
6	Parts for Element Assembling	-
6-1	Bolt (M4 x 30)	8
6-2	Hex. Bolt (M4 x 15)	2
6-3	Spring Washer (M4)	12
6-4	Nut (M4)	12
7	Balun Mounting	-
7-1	Balun CBL-2000	1
7-2	Balun Mount Bracket	1
7-3	U-Bolt (M5)	1
7-4	Spring Washer (M5)	2
7-5	Nut (M5)	2
7-6	Bolt (M5x12)	2
7-7	Feed Wire (w/contal nut)	2

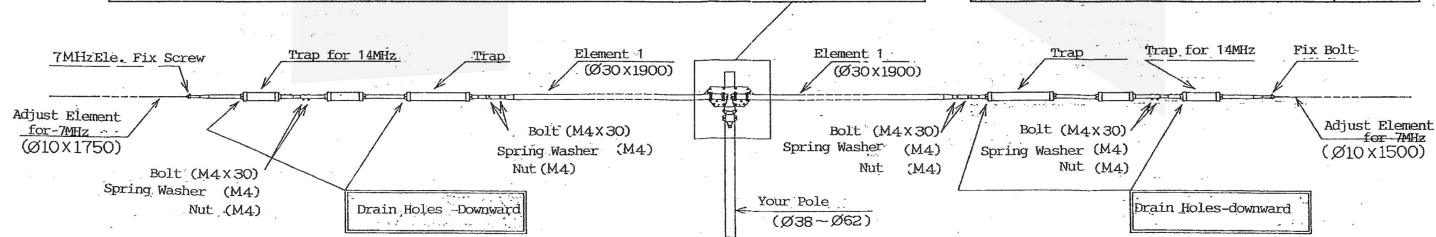

★ Full Assembly
(V- type)

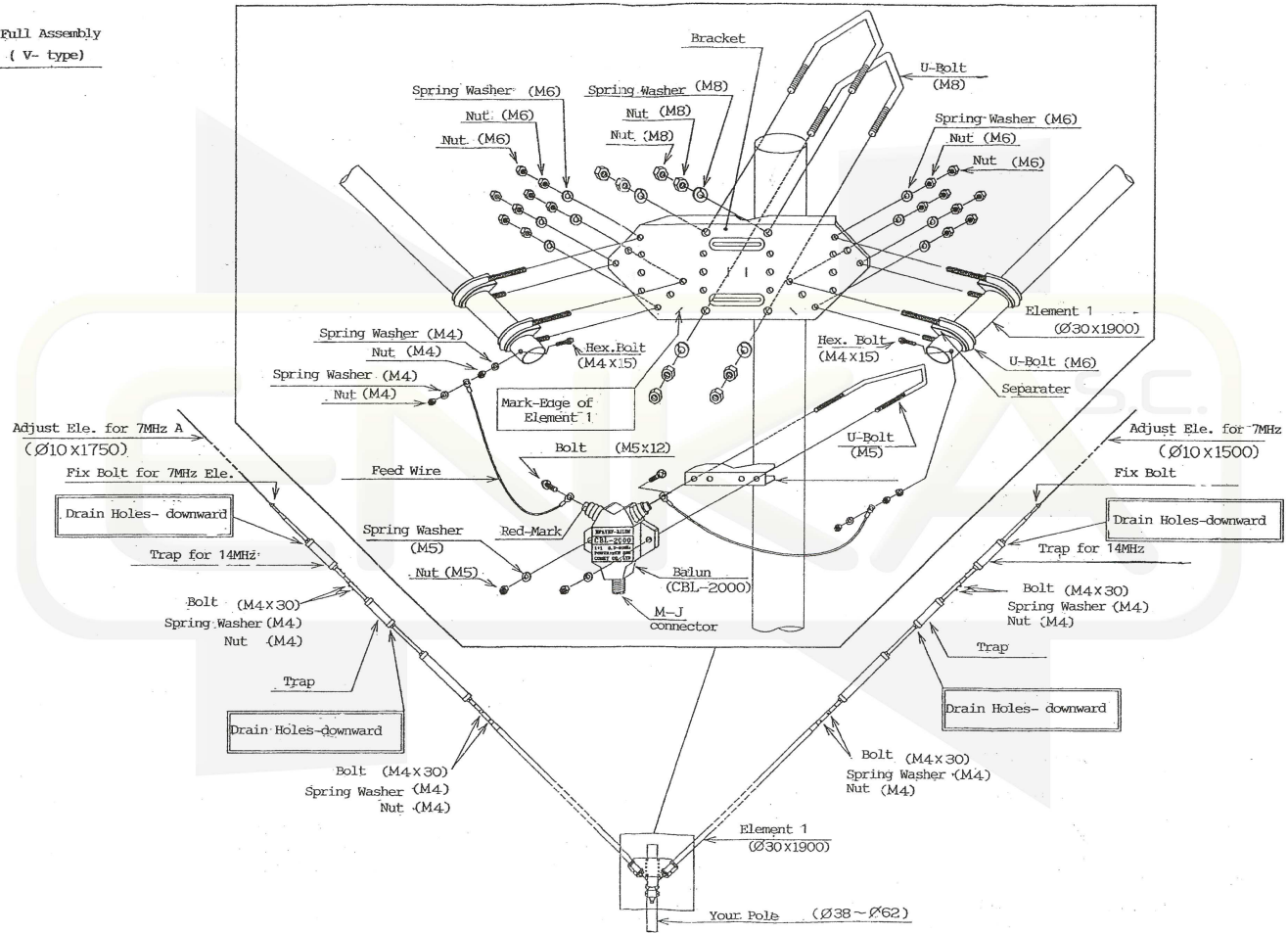

Frequency Adjustment:

- 1) Please connect SWR meter between H-422 and transceiver, as shown below:

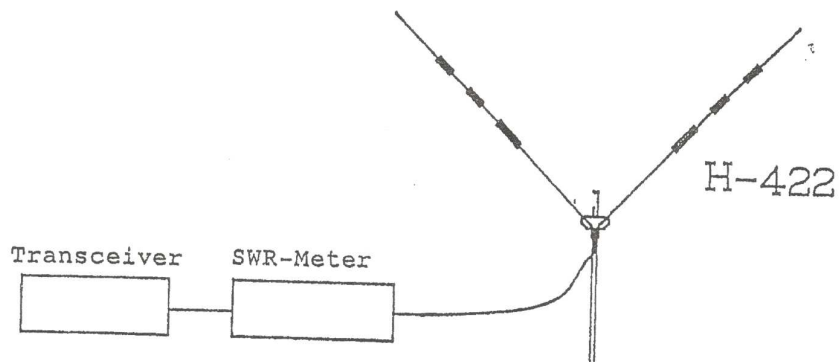

- 2) 14, 21 and 28MHz are Wide bands, then No Frequency adjustment is necessary. But, kindly check which location of is preferred.
- 3) Antenna location may give great influences on the 7MHz band. Then, adjust the length of 7MHz Adjust Ele. of both (A) & (B) watching your SWR meter.
Element sliding of 1cm can change the freq. of 15KHz.

Remarks:

- 1) Drain Holes on the Trap coils must be assembled to face Downward, to prevent water-inflow.
- 2) Kindly proceed necessary Water-Proof works, on the cable-joint section etc., using self-melting tape and/or vinyl tapes.

Change notification

Many thanks for your best choice of our products.

For your safety use:

Please read through this Operation Manual initially for correct assembling and proper operation.
At opening package and before assembling, please check all components are involved.

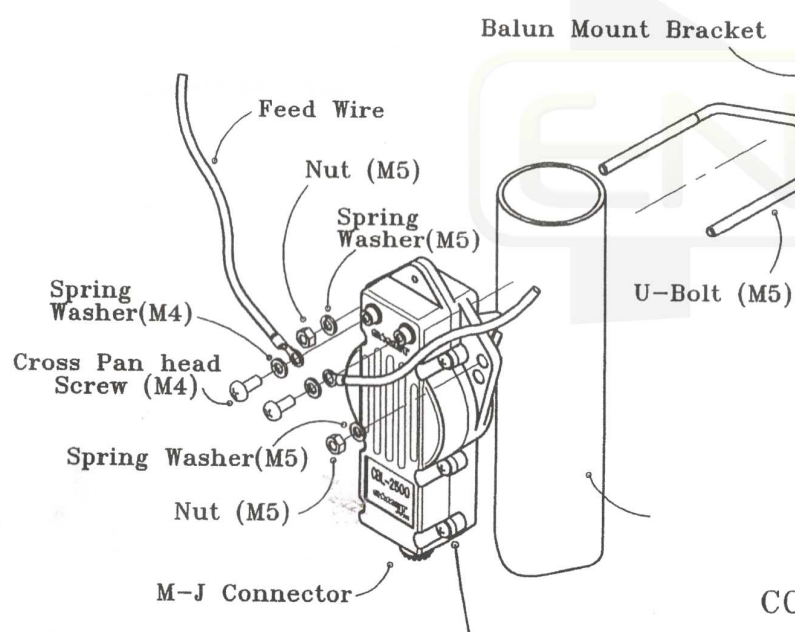

Balun:CBL-2500

- Change balun in CBL-2500.
- A left terminal is equivalent to the terminal of the red mark in CBL-2000 with a label indication aspect as the front.
- The mount bracket become needless.

COMET CO.,LTD.

eNka s.c. - Dystrybutor Produktów Firmy COMET w Polsce
www.comet-ant.pl 666 282 918; 666 282 919